

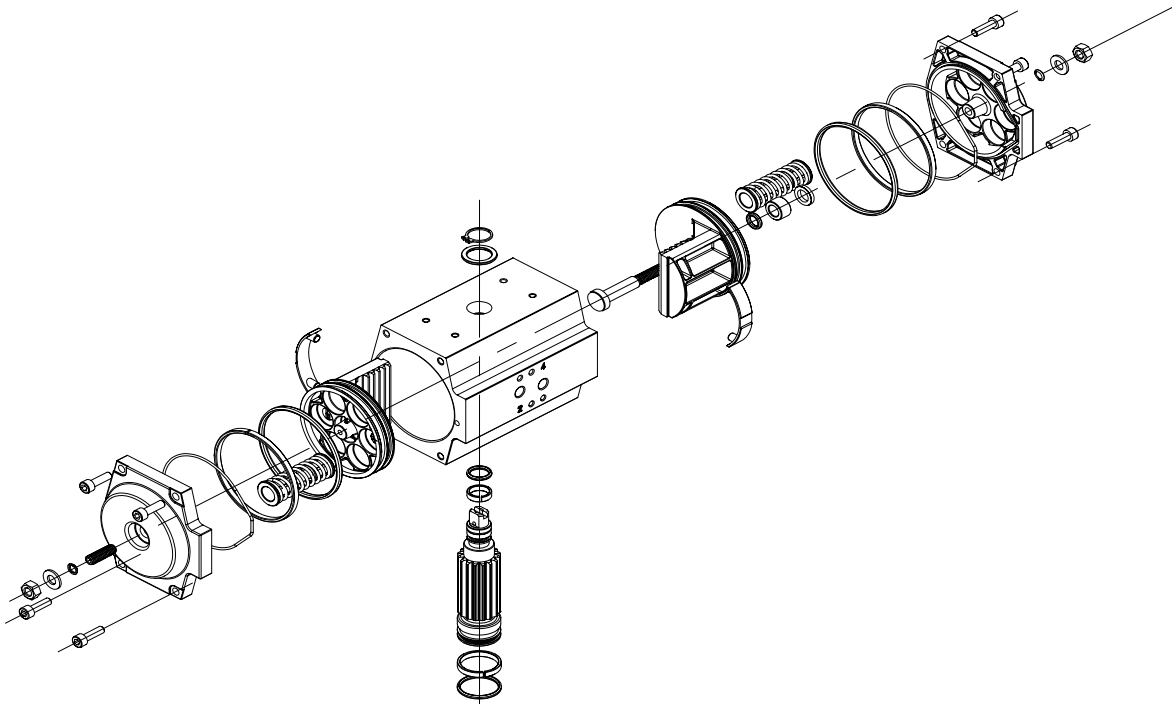

UNITORQ "M" SERIES RACK AND PINION PNEUMATIC ACTUATORS



**INSTALLATION
OPERATION &
MAINTENANCE
MANUAL**

6TH EDITION



TABLE OF CONTENTS

1-1	INTRODUCTION	3
2-1	STORAGE	3
3-1	OPERATING CHARACTERISTICS SPRING RETURN	3
3-2	OPERATING CHARACTERISTICS DOUBLE ACTING	4
4-1	ACTUATOR INSTALLATION	5-6
5-1	DISASSEMBLY PROCEDURE	6-7
5-2	LOW TEMPERATURE O-RING INSTALLATION	8
6-1	REASSEMBLY PROCEDURE	9-10
7-1	SPRING INSTALLATION	11
8-1	SOLENOID VALVE CHARACTERISTICS	11-12
8-2	SOLENOID VALVE INSTALLATION	13-14
8-3	SOLENOID VALVE INSTALLTION-EXPLOSION PROOF	14
9-1	SPEED CONTROL DEVICES	15
10-1	CCW TO CCCW CONVERSION	15-16
11-1	ACTUATOR SIZING	16
11-2	DOUBLE ACTING ACTUATORS	16
11-3	SPRING RETURN ACTUATORS	16-17
12-1	EXTENDED FINAL LIMIT STOPS	17
13-1	DOUBLE LIMIT STOPS	18
14-1	ACTUATOR DIMENSIONS	19
15-1	UNITORQ TECHNICAL INFORMATION	20
16-1	UNITORQ ACTUATOR MATERIAL TABLE	21
17-1	WARRANTY INFORMATION	22

1-1 INTRODUCTION

UniTorq offers one of the largest ranges of pneumatic rack and pinion actuators on the market. UniTorq actuators are designed to operate with pressurized air, but will function equally as well with hydraulic fluid, water or inert fluids. Our actuators are designed to operate within the pressure range of 20 PSIG to 150 PSIG and are offered in two styles: the Double Acting model and the Spring Return. The double acting model is available in 90°, 120°, 135° and 180° versions. The Spring Return version is available only as a 90° model. The double acting and spring return actuators can easily be field converted to other configurations by insertion or removal of the unique patented UniTorq spring cartridges.

2-1 STORAGE

All UniTorq actuators are factory lubricated for 2,000,000 cycles under normal operating conditions. The actuator ports are plugged to prevent liquids or other materials from entering the actuator during shipment. If the actuators are to be stored for a long period of time before installation, the units should be stroked periodically to prevent the seals from setting. (Note: the plugs must be removed in order to stroke actuator.) Storage should be indoors and the units should be protected against humidity and other harmful elements.

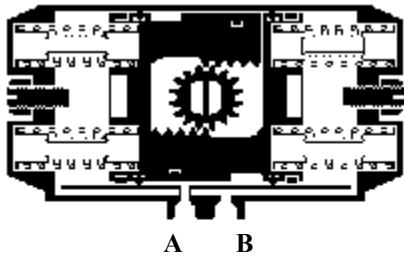

CLOSED POSITION
Figure 1.A

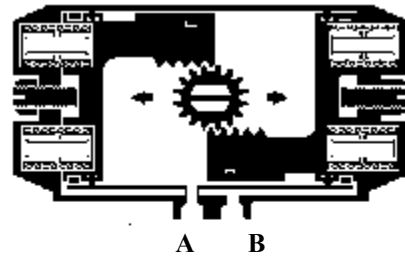

OPEN POSITION
Figure 1.B

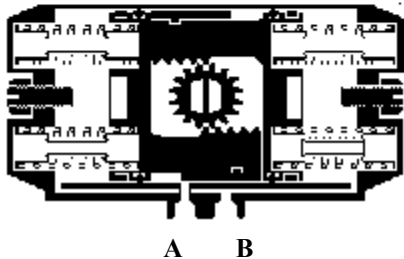

OPEN POSITION
Figure 1.C

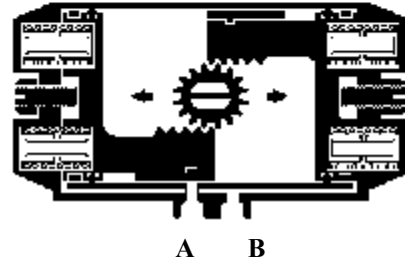

CLOSED POSITION
Figure 1.D

FIGURES 1. A - 1. D

Cut away top view of the UniTorq Spring Return actuator.

1. A-1.B Closed Clockwise

1.C-1.D Closed Counter Clockwise

The UniTorq actuator has simple operational characteristics. Port A is connected to the interior cavity between the pistons. Port B is connected to the end cap cavities. In figure 1.A, we see allowing air to exhaust through Port A, we have the normally closed position for the actuator. If we pressurize Port A, as in figure 1.B, the pinion will rotate in the counter clockwise direction and we see the open position of the actuator. (Note: in the case of air failure, spring return actuators will satisfy the conditions shown in Figures 1.A and 1.C using the stored energy of the springs.)

3-2 OPERATING CHARACTERISTICS (DOUBLE ACTING)

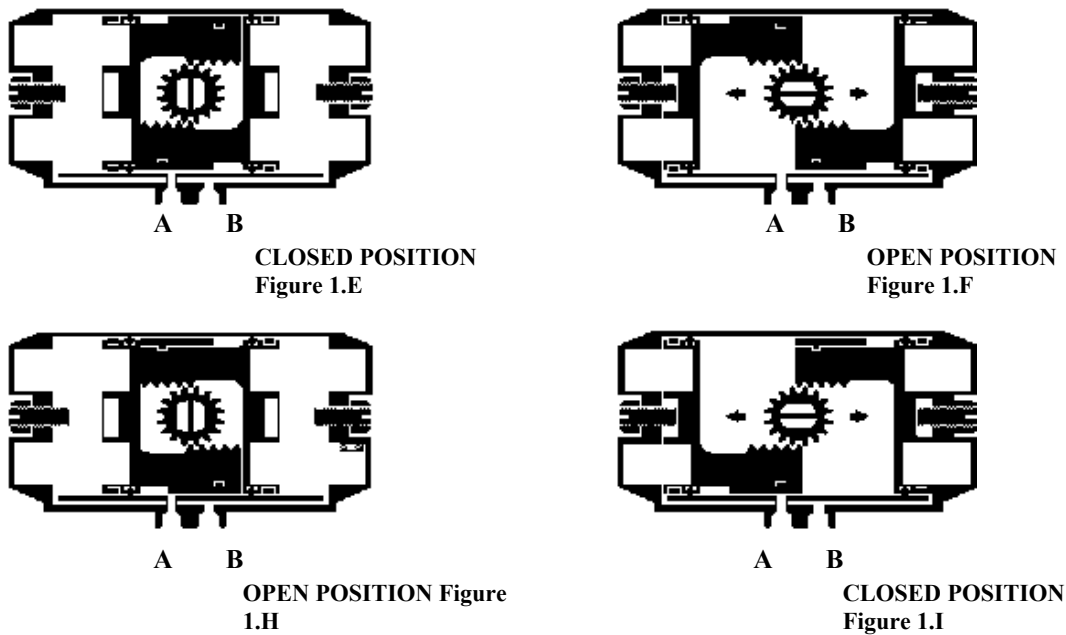

FIGURES 1.E - 2.I

Cut away top view of the UniTorq Double Acting actuator.

1. E-1.F Closed Clockwise

1.H-1.I Closed Counter Clockwise

The UniTorq double acting actuators has simple operating characteristics. Port A is connected to the interior cavity between the pistons. Port B is connected to the end cap cavities. In Figure 1.E, we see that pressurizing port B we have the closed position of the actuator. If we pressurize Port A and exhaust B, as in Figure 1.F the pinion will rotate in the counter clockwise direction and the actuator will go to it open position. Although the UniTorq actuator typically operates counter clockwise to open and clockwise to close, it is possible to reverse the operational mode. Figure 1.H & 1.I show the same double acting actuator with the piston orientation changed to convert the actuator from close clockwise to close counter clockwise (as described in Section 10-1 CCCW conversion).

4-1 ACTUATOR INSTALLATION

The UniTorq actuator is designed to be easily installed. The actuator comes with an ISO bottom mounting pattern and star broached on the pinion allowing for simpler coupling fabrication. Additional valve mounting patterns are available upon request.

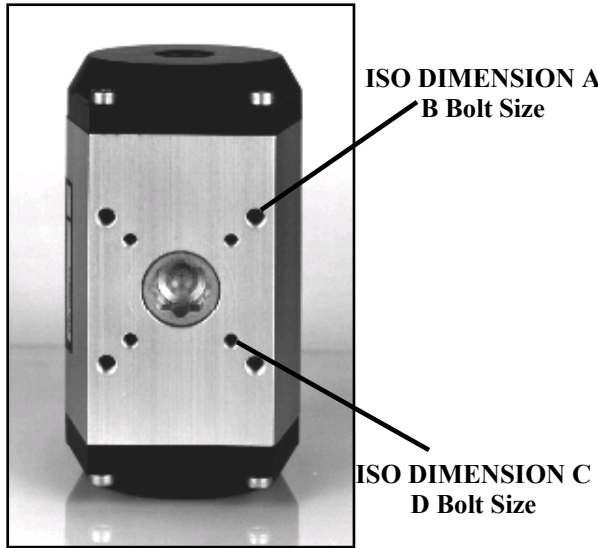

Figure 2
Bottom View of the
UniTorq actuator with
ISO dimensions.

MOUNTING DIMENSIONS

Table 1

ISO dimensions represents
Actuator mounting bolt circle.

Model	A Bolt Circle	B Bolt Size	C Bolt Circle	D Bolt Size
M10/11	1.65	10-32	1.42	10-32
M20/21	1.97	1/4-20	1.43	10-32
M30/31	2.76	5/16-18	1.97	1/4-20
M52/53	2.76	5/16-18	1.97	1/4-20
M73/74	2.76	5/16-18	1.97	1/4-20
M103/104	2.76	5/16-18	1.97	1/4-20
M148	4.02	3/8-16	2.76	5/16-18
M222	4.02	3/8-16	2.76	5/16-18
M295	4.02	3/8-16	2.76	5/16-18
M470	4.92	1/2-13	4.02	3/8-16
M586	4.92	1/2-13	4.02	3/8-16
M900	6.50	3/4-10	4.92	1/2-13
M1213	5.51	5/8-11	-	-
M2366	6.50	3/4-10	-	-
M2958	6.50	3/4-10	-	-
M3720	6.50	3/4-10	-	-

1. Insert coupling into the actuator and the valve stem to check for proper fit. **NOTE: IF ACTUATOR IS DOUBLE ACTING, CHECK TO SEE IF PINION IS IN ITS REQUIRED POSITION.**
2. Make sure valve is in the normal position before proceeding. Figure 3 describes the correct normal pinion position for all CCW and double acting UniTorq actuators. (Note: the pinion for CCCW actuators will be rotated by 90°)
3. Install mounting bracket on to valve and hand tighten all fasteners. (Be sure not to fully torque bolts until entire assembly is correctly aligned and installed.)
4. Place coupling on valve stem and position actuator over coupling and onto mounting bracket. Align valve and actuator assembly so as to eliminate shear forces. Tighten all assembly fasteners to the appropriate torque.

Table 2

Bolt Size
10-32
1/4-20
5/16-18
3/8-16
1/2-13
3/4-10
5/8-11

Figure 3
Figure 3 shows an actuator in the normal position (CCW operation) with the pinion flats perpendicular to the centerline of the actuator.

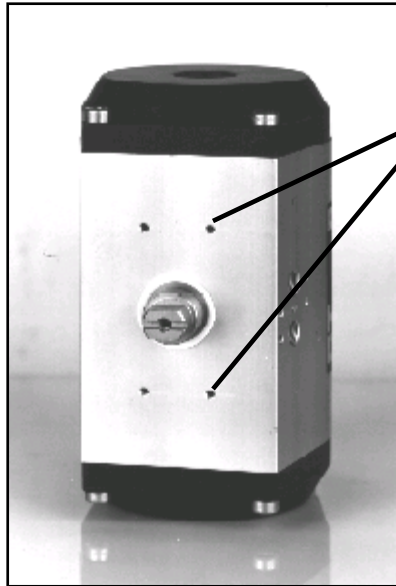

Limit Switch and
Positioner Namur
mounting pad

5. Actuate pneumatically several times to ensure that the coupling is not binding. If unit does not function properly, disassemble and repeat steps 1-5, as detailed in section 5-1. If problems persist, contact your local UniTorq representative.
6. After all mounting procedures are completed, it is necessary to set the travel stops to ensure proper rotation. The UniTorq travel stop allows for a range of 95° to 85°. If a larger range is necessary, consult section 12-1 for information on extended travel limit stops.
NOTE: IMPROPER SETTING OF TRAVEL STOPS CAN REDUCE ACTUATOR'S LIFE.
7. Rotate valve assembly to desired position. (It is best to consult valve I & M sheet to determine the correct set point for the valve.)
8. Loosen both sealing nuts. Torque travel stops until the stops contact the pistons. Be sure not to alter the valve position while setting the travel stops. Torque the sealing nuts until secure. Retest actuator to assure that there are no end cap air leaks.

5-1 DISASSEMBLY PROCEDURE

1. Disconnect all electrical and air supplies from the actuator.

CAUTION:
NEVER DISASSEMBLE AN ACTUATOR THAT IS UNDER PRESSURE

2. Remove actuator from mounting bracket and coupling (limit switches and Positioner when applicable) and place in clean environment.
3. Match the actuator and end caps, allowing for the correct reassembly of the actuator.
NOTE: IF THE END CAPS ARE NOT REPLACED WITH THE CORRECT ORIENTATION, THE ACTUATOR WILL NOT FUNCTION PROPERLY. END CAPS MUST BE REINSTALLED WITH "UP" SIDE ON TOP.
4. Remove the eight socket head cap screws and remove end caps.

5. Remove O-Rings from end cap. (Note: if actuator has not been in service, it will be necessary to replace the O-Ring set.)

6. Rotate pinion in Counter Clockwise direction (Note: if unit is a CCCW, rotation will be in opposite direction) until pistons are far enough from cylinder to be removed by hand. If pistons are too difficult to remove by hand, it is acceptable to use a pair of pliers to assist in their removal. (Note: be sure not to scar the surface of pistons.) Remove both pistons, noting the orientation of the pistons, so that during reassembly the pistons will be replaced in the same orientation. (Figure 4.)



Figure 4

This figure shows the actuator pinion rotated until pistons disengage from pinion gears.

7. Remove snap ring and delrin washer from top of pinion. Place the actuator between two blocks of wood so that the pinion is free to be removed through the bottom of the actuator body. Using a rubber mallet, lightly tap the top of the pinion. When the pinion is loose from the body remove the pinion through the bottom (Figure 5).



Figure 5

This figure demonstrates the removal of pinion through the bottom of the actuator.

8. If Actuator has been in service the following components should be replaced. The O-Rings and guide kits contains the following items: (Note: a repair kit contains both the O-Ring set and the guide set.)

Item #	Qty	Description
1	2	O-Ring (Piston)
2	2	O-Ring (End Cap)
3	1	O-Ring (Shaft Upper)
4	1	O-Ring (Shaft Lower)
5	2	Air Passage O-Ring*

Table 3.A

O-Rings Set (Required Parts)

* = M3720 Only

Item #	Qty	Description
1	1	Shaft (Upper Guide)
2	1	Shaft (Lower Guide)
3	2	Piston Guide Skate
4	2	Piston Guide O-Ring
5	1	Pinion Washer

Table 3.B

Guide Set (Required Parts)

5-2 LOW TEMPERATURE O-RING INSTALLATION

1. Disassemble actuator as described in section 5-1.
2. Using a flat head screwdriver, remove the O-Rings from the various actuator components: (See section 16-1 for actuator parts list.)
 - a. Piston O-Rings (2 places)
 - b. End Caps (2 places)
 - c. Upper Pinion O-Ring (1 place)
 - d. Lower Pinion O-Ring (1 place)
 - e. Air Passage O-Ring (2 places) 3720 only
3. Using mineral spirits (or other mild solvent), remove the lubrication from each actuator component. (Note: clean all surfaces thoroughly prior to installation of new O-Ring set.)
4. Separate O-Rings and determine the locations for installation:
 - a. Piston O-Rings: will be the thickest O-Rings (2 pieces), (*See Note.*)
 - b. End Cap O-Rings: will have the largest O-Ring diameter (2 pieces), (*See Note.*)
 - c. Pinion O-Rings: of the 4 remaining O-Rings, the largest is installed in the lower pinion O-Ring groove. The second largest is installed in the upper pinion O-Ring groove.
 - d. 3720 Air passage seals: the last 2 O-Rings are installed between the end cap and the actuators internal air passage.

(Note: if these O-Rings are not properly seated, they may be pinched during reassembly and subsequently leak.)

5. Install low temperature O-Ring set. If the O-Rings are difficult to install, the O-Rings may be slightly stretched and lubricated to ease installation. (Note: be sure to use the lubricant provided when lubricating the O-Rings.) When installing the end cap O-Rings, be sure to seat the O-Ring properly.
6. APPLY LUBRICANT TO THE INTERNAL PORTIONS OF THE ACTUATOR:
 - A. INNER BORE OF ACTUATOR.
 - B. PISTON WEAR SURFACES (PISTON SKATE, PISTON BEARING & PISTON O-RING).
 - C. PISTON RACK (APPLY ON THE FULL LENGTH OF THE PISTON RACK).
 - D. PINION GEAR TEETH.
 - E. PINION WEAR SURFACES AND O-RINGS (BOTH UPPER AND LOWER AREAS).
7. ASSEMBLE ACTUATOR AS DESCRIBED 6-1.

6-1 REASSEMBLY PROCEDURE

1. Inspect all wear surfaces for excessive wear or possible damage.

CAUTION:
**BE SURE THAT ALL PARTS ARE STILL WITHIN FACTORY SET
TOLERANCES BEFORE REASSEMBLY**

2. Make sure all metallic parts are clean and free of any nicks or burrs.
3. Install O-Rings (and wear surface skates and bearings when applicable) on pistons, end caps and pinion.
4. Lubricate the inside bore of the cylinder, O-Rings, piston skate, piston guides, pinion bearing with compatible lubricant. In the case of a low temperature application (i.e. below 0° F), consult UniTorq for correct lubricant type. **NOTE: ALL O-RINGS SHOULD BE REPLACED AS A MATTER OF POLICY IF THE ACTUATOR HAS BEEN IN SERVICE.**
5. Insert pinion into actuator body. Install pinion washer and snap ring.
6. Insert pistons into cylinder body until the pistons begin to mesh with the pinion. Make sure that the pistons are symmetrically placed inside the cylinder body. This is very important. Be sure that tooth engagement is even on both pistons. If the pistons are not tracking properly remove and reinsert pistons.
7. Apply equal pressure on each piston until they are fully engaged with the pinion. Rotate pinion until actuator is fully closed.
8. Check the top of pinion for correct orientation. If the pinion flats are perpendicular to the cylinder body then proceed to the next step.
(Note: For CCCW applications, the pinion flats should be parallel to the cylinder body.) If the pinion is incorrectly positioned, as demonstrated in figure 6, then proceed to part 8b.



8b. Turn actuator up on its side. Rotate pinion counter clockwise until both pistons disengage from pinion. Rotate pinion with a wrench to correct position. Apply light pressure to pistons until pinion and pistons engage. Close actuator and check for correct pinion orientation. (Repeat this step as many times as necessary to get the correct orientation.)

9. Insert springs. (For information on the loading of springs refer to section 7-1.)

10. Replace end caps, being sure to position them in same orientation as before.
NOTE: TORQUE SCREWS IN ALTERNATING ORDER TO ENSURE THAT THE O-RING SEATS PROPERLY.

11. End cap screws should be torqued, in alternating order, to the factory standard. Refer to Table 4 for correct bolt torque specifications.

UniTorq Model	Fastener UNC	Fastener Metric	Torque Spec. lbs-in/N -m
M20/21-M30/31	#10-32	M5	70/8
M52/53-M73/74-M103/104	1/4-20	M6	106/12
M148-M222-M295	5/16-18	M8	133/15
M470-M586	3/8-16	M10	177/20
M900-M1213	1/2-13	M12	250/28
M2366-M2958-M3720	9/16- 12	M14	354/40

Table 4
End cap fastener torque specifications.

12. Pressurize Port B (Fig 1A-1D) on actuator body to test for air leaks. Leaks can occur around pinion and between end cap and body mating surfaces. If an air leak is found near the end cap, remove end cap and check for proper O-Ring seating. If O-Rings appear to be in good condition, repeat step 11.

7-1 SPRING INSTALLATION

UniTorq actuators have the unique ability to be field converted from Double Acting to a Spring Return actuator very easily by adding the spring configuration inside the end caps. (Note: refer to the instructions below.) The UniTorq actuator can accept up to 6 cartridge springs in each end cap, but not less than 2 spring cartridges per end cap. The number of cartridge springs loaded into the actuator affects the amount of torque the actuator will be able to generate during the closing and opening cycles. Review sections 11-X on actuator sizing for correct procedures in selecting spring combinations.

1. Match mark cylinder body and end caps to ensure proper assembly. **NOTE: COUNT OUT THE CORRECT NUMBER OF SPRINGS TO BE USED BEFORE DISASSEMBLY IS PERFORMED.**
2. Remove end caps. (Count out correct number of springs before attempting to convert unit.)

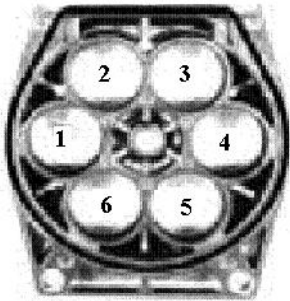

Figure 7
Right view of end cap

Total # of Springs	2	3	4	5	6
Spring Location (Right cap)	1/4	1/3/5	2/3/5/6	1/3/4/5/6	All Positions
Spring Location (Left Cap)	1/4	1/3/5	2/3/5/6	1/3/4/5/6	All Positions

Table 5
Spring orientation chart

3. Insert the correct number of springs in **EACH** end cap in the accordance with Table 5 and Figure 7. (Example : Model # M30 K4-4 = 4 springs/end cap. Total of 8 springs.)
4. In the case of a K5 actuator be sure to offset the empty spring socket. Table 5 shows the correct spring locations for the left and right end caps.

8-1 SOLENOID VALVE CHARACTERISTICS

UniTorq direct mount Solenoid Valves are permanently lubricated and are designed for long life. These solenoid valves are specially designed to be easy installed on pneumatic actuators. The solenoids come equipped with BUNA O-Rings to seal the valve ports to the actuator body.

Operation:

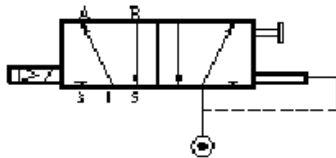

Single Coil

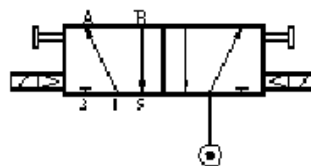

Dual Coil

Single Coil Solenoids:

Port P is the supply port and ports R1 and R2 are the exhaust ports for both the dual coil and single coil types. The exhaust ports may be equipped with silencers or speed controls to control the actuation speed. Ports A and B are the actuator input ports. In the normal position air goes from the supply port (Port P) to port B. During solenoid activation the flow will be from the supply port (Port P) to port A.

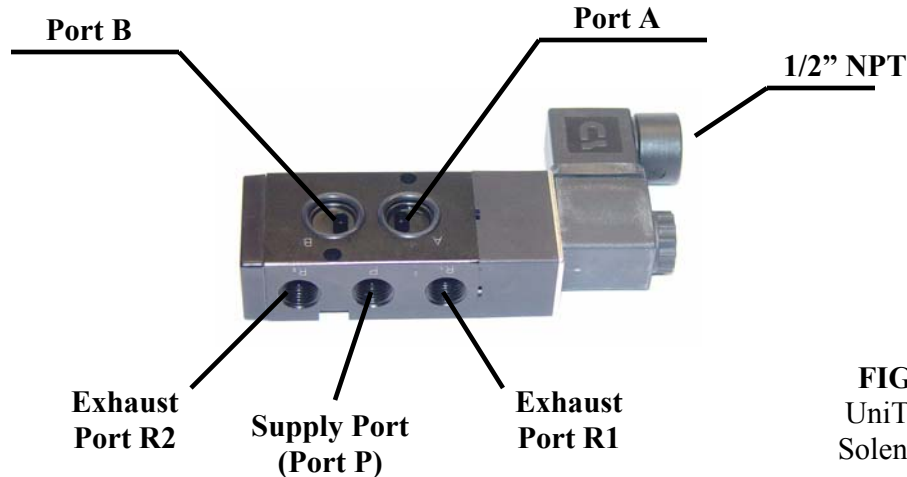

FIGURE 8
UniTorq SV 1
Solenoid Valve

Dual Coil Solenoids:

Dual coil solenoids can be operated in two different modes.

Mode 1: Energize solenoid A to connect the Supply Port to Port A. The spool which directs the air flow will respond in less than one second. After the spool has adopted its new position the coil can be de-energized. To direct the air flow to Port B energize solenoid B which can also be de-energized after the spool has been moved.

Mode 2: All of the previous conditions apply except that the coil moving the spool can be left energized. The only important consideration is that **YOU MUST DE-ENERGIZE COIL A BEFORE ENERGIZING COIL B.** The converse is also true. De-energize Coil B before energizing Coil A.

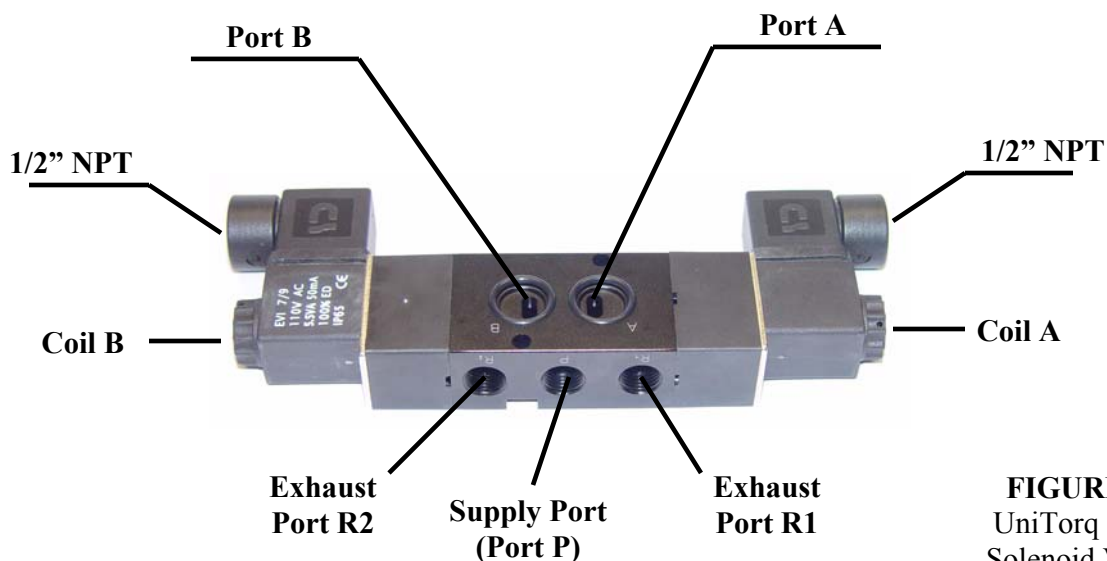

FIGURE 9
UniTorq SV 2
Solenoid Valve

8-2 SOLENOID VALVE INSTALLATION

Note: Make sure that Port O-Rings are correctly placed inside O-Ring groove.

1. Affix solenoid to actuator and tighten screw to 70 in-lbs.
2. Disconnect solenoid wire hood. Wire terminal block and replace hood. (See Figure 10)

Note: Terminal designation

1. Positive
 2. Neutral
 3. Ground
3. Energize solenoid valve several times and test for leaks and proper operation. Note: Solenoid nut should be hand tight.

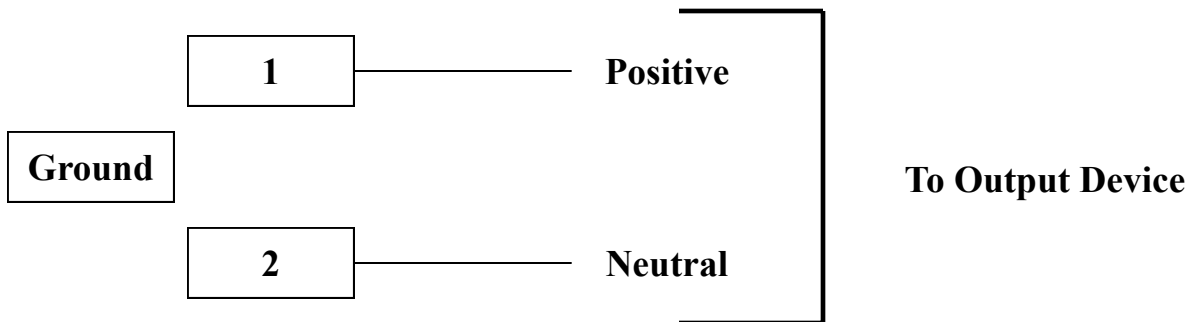

Figure 10

Note: Wiring diagram is the same for all voltages.
(24/48/120/220 AC : 12/24/48/120 DC)

Manual Override:

The UniTorq solenoid valve comes equipped with a manual override. A small blue lever located between the valve body and the coil positioned perpendicular to the long axis of the valve body allows for the overriding of the solenoid if necessary. The normal position for the switch will be perpendicular to the long axis of the valve body. Press blue lever for momentary override. Press blue lever and turning 90° in the counter clockwise direction will manually lock the solenoid in the override position until the lever is returned to its original position.

Solenoid Classification:

The UniTorq solenoid valve is designed to the NEMA 4 and 4X standards. The UniTorq solenoid valve can be adapted to the 7 and 9 classifications by installing a special solenoid on the standard valve body.

NEMA 4, 4X: Watertight and Dust tight - indoor & outdoor. Protects against windblown dust, rain, splashing water and hose directed water and is corrosion resistant.

NEMA 7, 9: All of the above standard plus: Class I & Class II, indoor hazardous locations, explosion proof. Which includes groups A, B, C, D, E, F, and G.

Specifications:

1. SV1 NAMUR 5 Way NEMA 4 solenoid valve with standard Namur mount (M10/11 - M3720)

Specifications:

Nominal Voltage: 110 VAC +/- 10%

Port Dimensions: Port A = 1/4" NPT (Ports R1 & R2 = 1/4" NPT)

Power: 50/60 Hz AC at 5.5VA (50maAC)

Pressure Range: Min - 29 psi. / Max - 145 psi.

CV Factor: 1.4

In addition to these two basic models UniTorq also offers a NEMA 4, 7, and 9 upgrade for explosion proof applications. The UniTorq explosion proof solenoid can easily be mounted to the standard UniTorq valve block with the addition of a spacer block and a valve adapter kit.

2. SV1 NAMUR 5 Way NEMA 4, 7, and 9 solenoid valve with Namur Mounting (M10/11 - M3720)

Specifications:

Nominal voltage: 110VAC +/- 10%

Port Dimensions: Port A 1/4" NPT (Ports R1 & R2 = 1/4" NPT)

Power: 60 Hz AC at 6.8VA (57maAC)

Pressure Range: Min - 29 psi. / Max - 145 psi.

CV Factor: 1.4

8-3 SOLENOID VALVE INSTALLATION - EXPLOSION PROOF

The UniTorq Nema 4 solenoid valve can be converted to comply with the NEMA 7 & 9 standard by adding an explosion proof coil.

9-1 SPEED CONTROL DEVICES

UniTorq actuators are designed to enable the user to obtain the lowest possible cycle time. In some instances, it is desirable to enable the actuator to cycle more slowly than the standard speed. In these cases a speed control device is necessary. UniTorq can provide speed controls to obtain varying cycle times.

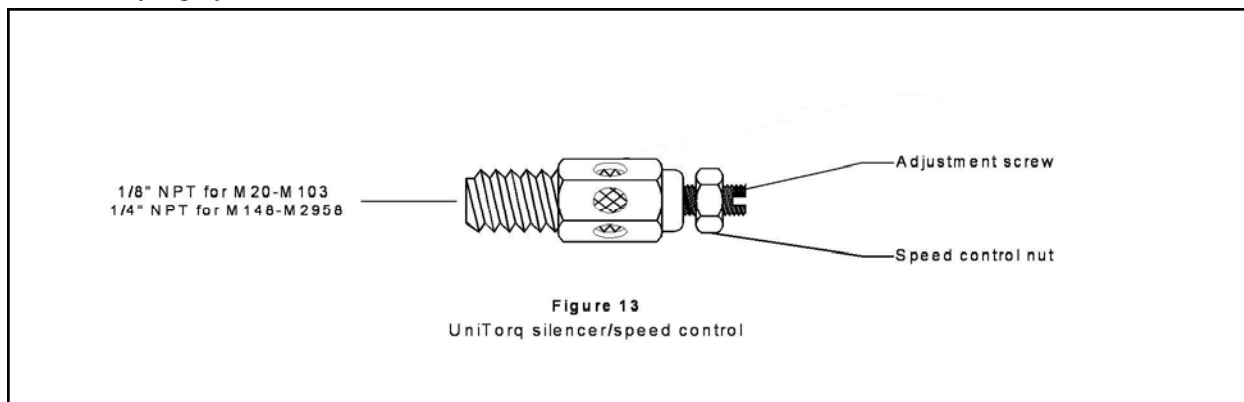

When using speed controls, coat the speed control threads with pipe sealing compound prior to installation to avoid air leakage. The cycle time can be changed by loosening the speed control nut and then tightening or loosening the adjustment screw. To increase cycle time, tighten the adjustment screw. To decrease the cycle time, loosen the adjustment screw. (Note: be sure to tighten the speed control nut prior to commencing operation.)

10-1 CCW TO CCCW CONVERSION

UniTorq actuators typically come from the factory as Closed Clock-wise (CCW) units. In the event that the actuator needs to be changed from CCW to a Closed Counter Clock-wise (CCCW) actuator. UniTorq actuators can be easily field converted to this configuration.

1. Remove end caps, pistons and the pinion as described in the disassembly procedure. Prior to reassembly, rotate both pistons 180° along the long axis of the piston. (See Figure 14.) Upon rotation of pistons, reassembly can be accomplished by following the reassembly instruction in Section 6-1 Steps 1-12 of this manual.

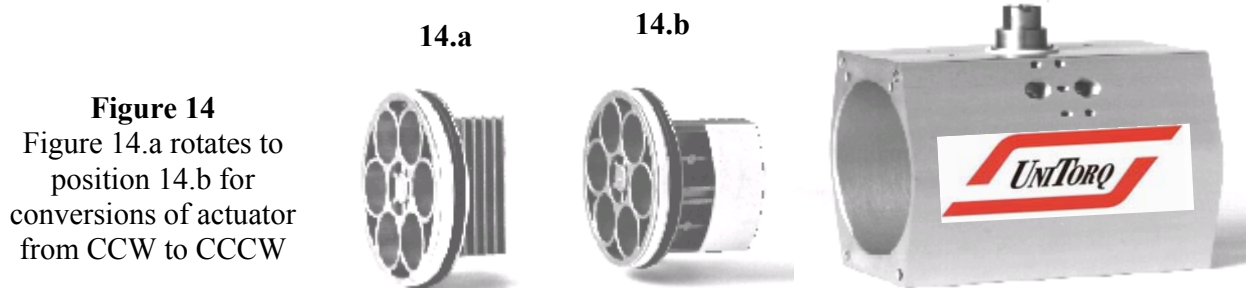

NOTE: REPLACE SPRINGS PRIOR TO TESTING IF NECESSARY

2. After this procedure has been accomplished, you should be able to put air into the right air port and move the actuator counter clock-wise. When air is placed in the left port, the actuator now rotates in the clockwise direction.

11-1 ACTUATOR SIZING

Prior to actual sizing; it is important to obtain certain information. Key numbers to obtain are as follows:

- Torque required to open the valve (Break Torque)
- Torque required to close: the valve seating Torque)
- Torque required to rotate the valve (Running Torque)
- Supply air pressure (To Actuator)
- Differential Pressure of Valve/Damper

Obtaining the above information allows you to properly and effectively size the actuator. (Note: double acting actuators have a constant torque throughout their stroke. When determining the air supply pressure, it is important that you use the minimum air pressure that the actuator will experience and not the average air supply pressure. If an actuator is supplied by a lower air pressure than it is sized for, failure or improper performance will occur.) UniTorq offers a Windows based sizing program for double acting and spring return actuators to make sizing easier. Please refer to your local sales representative for more information or to obtain the latest edition.

11-2 DOUBLE ACTING ACTUATORS

1. Select the largest torque (opening or closing torque) and increase that number by 10%. (Note: adding 10% will ensure an acceptable factor of safety. The data published in the sizing table indicates the actuator's maximum capability for a given pressure.)
2. Look in the column that corresponds to the supply pressure, you have selected. Move down the chart until you have found a torque which is larger than the torque determined or your application. After you have found the correct value move across the table horizontally to determine the correct actuator.

11-3 SPRING RETURN ACTUATORS

1. Multiply both your valve closing torque and your valve opening torque by 20%. (This will provide an acceptable factor of safety.) **NOTE: THE VALVE CLOSING TORQUE CORRESPONDS TO THE SPRING END COLUMN AND THE VALVE OPENING TORQUE CORRESPONDS TO THE ACTUATOR AIR PRESSURE COLUMN.**

Example: Given information-Valve opening torque (VOT) = 800 in-lbs.

Valve closing torque (VCT) =750 in-lbs.

1. Increase by 20% + VOT = 960in-lbs : 20% + VCT = 900in-lbs
2. Refer to table below:

TABLE 6
Sizing Sample
Chart

Model	Type	Supply Pressure 80 Psi Air Stroke Torque	Spring Stroke Torque
	K3	1690 (in-lbs)	774 (in-lbs)
M295	K4	1283	1033
	K5	876	1290

NOTE: THIS TABLE IS AN EXCERPT FROM THE SIZING CHART
PROVIDED BY UNITORQ.

2. To satisfy all conditions of this application we compare the VOT to the column 1 and the VCT to column 2. Since the M295 K4 satisfies both conditions, we select this actuator.

12-1 EXTENDED FINAL LIMIT STOPS

The UniTorq line of actuators also includes a special feature called the extended final limit stop. This feature allows for the adjusting of the total amount of rotation of an actuator. To install this feature, perform the following steps: (Note: be sure to follow the disconnection procedure outlined in section 5-1.)

1. Remove the sealing nut and end stop from both end caps. Sealing nuts have a small groove cut into the bottom to allow for the sealing O-Ring to be seated. Be sure to replace the O-Ring when replacing the sealing nut.
2. After disassembly, install the extended limit stops in the manner described in the installation section 4-1, parts 6 through 8. (Note: this information refers to the travel stops, but in this configuration the travel stops and the extended limit stops act in the same manner.)

13-1 DOUBLE LIMIT STOPS

The new DLS configuration allows for quicker and safer stroke travel adjustment with no increase in external dimensions or additional caps. Adjustments are easier than ever before with improved strength and performance.

The new DLS actuator allows for approximately 5 degrees of stroke over-travel in each direction. The effective operation of the actuator is now -5° to 95° , with adjustment of over 10° at either end of travel. This will allow the user to fine tune the actuator for optimal valve performance and life.

The travel stops are located at the end caps. Facing the actuator with the air ports nearest to you the open (piston in) travel stop is located on the left. The closed (piston out) travel stop is on the right end cap. It is the gold zinc plated nut. To adjust the open position simply back off the lock nut and turn the setscrew in clockwise (CW) to reduce travel or out counter clockwise (CCW) to increase travel. To set the close stop, loosen the locknut on the right side travel stop and screw it set screw inwards, clockwise (CW), to increase travel or outwards, counter clockwise (CCW), to decrease the travel.

ACTUATOR SHOWN IN OPEN POSITION

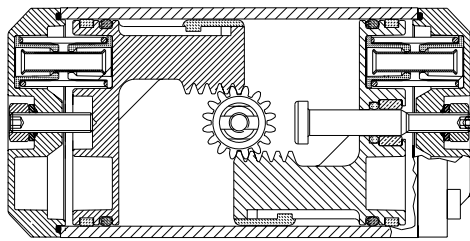

ACTUATOR SHOWN IN CLOSED POSITION

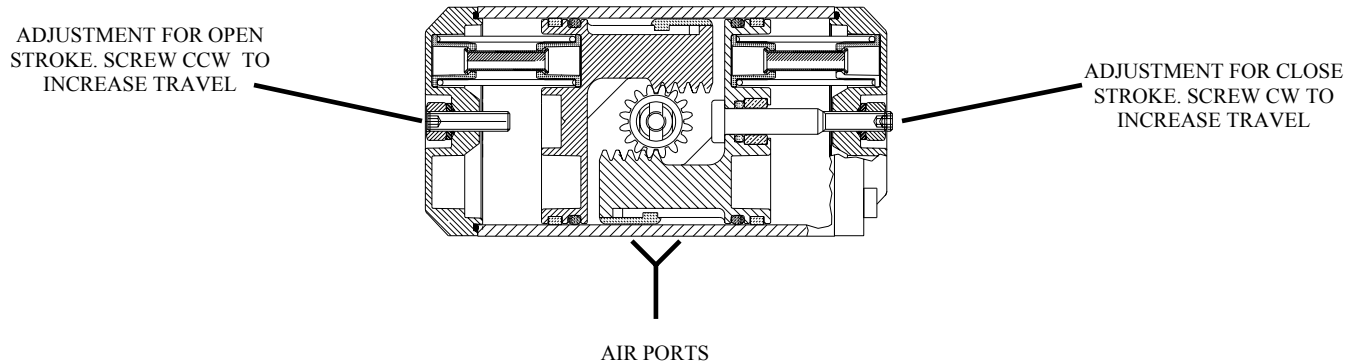

14-1 ACTUATOR DIMENSIONS

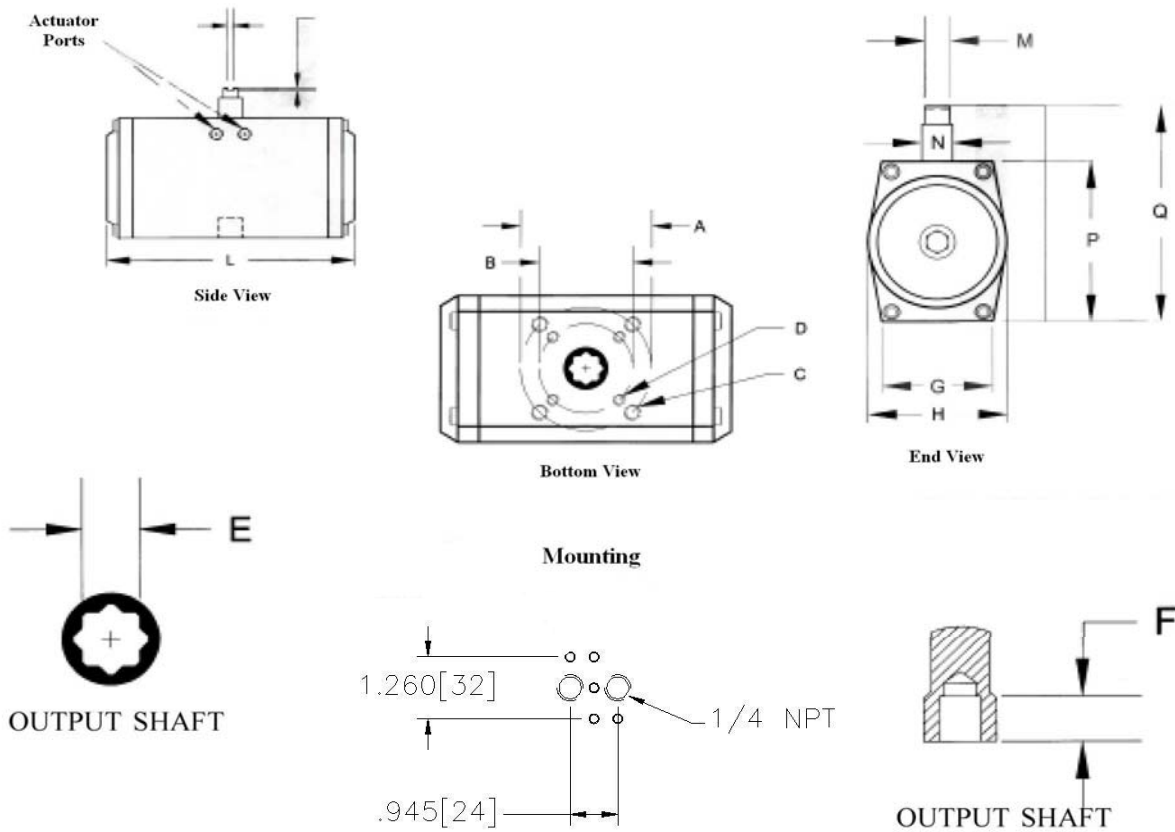

MODEL	A	F0	B	F0	C*	D*	E	F	G	H	I	L	L1*	M	N	P	Q	R	S
M10/11	1.65	F04	1.42	F03	#10-32	#10-32	9 or 11mm	0.55	2.02	2.54	0.35	4.33	-	0.47/0.551	-	2.60	3.50	1/4	0.94
M20/21	1.97	F05	1.42	F03	1/4-20	#10-32	14mm	0.71	1.97	2.32	0.39	5.00	7.52	0.47/0.55	0.79	2.91	3.82	1/4	0.94
M30/31	2.76	F07	1.97	F05	5-16-18	1/4-20	14mm	0.71	2.36	2.76	0.39	5.24	7.99	0.47/0.55	0.79	3.46	4.37	1/4	0.94
M52/53	2.76	F07	1.97	F05	5-16-18	1/4-20	17mm	0.75	2.56	3.27	0.39	6.10	9.29	0.55	1.02	3.94	4.84	1/4	0.94
M73/74	2.76	F07	1.97	F05	5-16-18	1/4-20	17mm	0.75	2.56	3.58	0.39	6.97	10.63	0.55	1.02	4.25	4.95	1/4	0.94
M103/104	2.76	F07	1.97	F05	5-16-18	1/4-20	17mm	0.75	2.76	3.94	0.55	7.99	12.36	0.79	1.38	4.61	5.55	1/4	0.94
M148	4.02	F10	2.76	F07	3/18-16	5/16-18	22mm	0.96	3.54	4.72	0.55	8.50	12.72	0.79	1.97	5.51	6.45	1/4	0.94
M222	4.02	F10	2.76	F07	3/18-16	5/16-18	22mm	0.96	3.54	4.72	0.79	11.18	16.85	1.10	1.97	5.51	6.71	1/4	0.94
M295	4.02	F10	2.76	F07	3/18-16	5/16-18	22mm	0.98	4.06	5.39	0.79	11.42	17.76	1.10	1.97	6.30	7.51	1/4	0.94
M470	4.92	F12	4.02	F10	1/2-13	3/8-16	27mm	1.07	4.33	6.77	0.79	13.27	-	1.10	2.36	7.80	9.70	1/4	0.94
M586	4.92	F12	4.02	F10	1/2-13	3/8-16	27mm	1.07	4.33	6.77	1.10	14.49	22.36	1.42	2.36	7.80	9.70	1/4	0.94
M900	6.50	F16	4.92	F12	3/4-10	1/2-13	36mm	1.57	5.31	8.82	1.26	16.62	-	1.42	2.84	10.00	11.77	1/4	0.94
M1213	5.51	F14	-	-	5/8-11	-	36mm	1.57	5.31	8.82	1.26	17.72	27.24	1.57	2.95	10.00	11.77	1/4	0.94
M2366	6.50	F16	-	-	3/4-10	-	46mm	1.57	6.26	10.71	1.26	23.07	35.63	1.57	3.54	11.89	13.66	1/4	0.94
M2958	6.50	F16	-	-	3/4-10	-	46mm	1.53	6.26	10.71	1.26	23.07	-	1.57	3.54	11.89	13.66	1/4	0.94
M3720	6.50	F16	-	-	3/4-10	-	46mm	1.61	6.30	14.17	1.26	26.89	-	1.58	2.96	14.17	15.94	1/2	1.97

15-1 UNITORQ TECHNICAL INFORMATION

MODEL	90°	120°	180°	K6
M10/11	1.00	-	-	1.20
M20/21	1.98	2.20	2.65	2.20
M30/31	2.98	3.26	3.97	3.42
M52/53	4.30	4.74	5.59	5.07
M73/74	5.51	5.95	7.94	6.39
M103/104	7.39	8.16	11.25	8.38
M148	10.58	11.47	13.56	12.79
M222	14.99	16.90	20.68	17.86
M295	18.74	20.73	26.02	22.49
M470	31.00	-	-	39.80
M586	34.40	39.69	55.79	42.78
M900	61.50	-	-	83.10
M1213	68.80	81.14	106.94	86.66
M2366	132.32	146.63	173.60	180.81
M2958	106.97	177.60	-	209.48
M3720	205.00	-	-	267.00

**ACTUATOR WEIGHT
IN POUNDS**

**AIR CONSUMPTION
CUBIC INCHES PER CYCLE**

TYPE	CYCLE TIME (Sec.)
M10/11	0.123
M20/21	0.158
M30/31	0.214
M52/53	0.333
M73/74	0.429
M103/104	0.444
M148	0.461
M222	0.600
M295	0.857
M470	1.280
M586	1.620
M900	2.790
M1213	3.330
M2366	6.000
M2958	7.500
M3720	9.600

MODEL	90°	120°	180°	K6
M10/11	12.8	-	-	6.7
M20/21	15.3	17.1	28.1	7.3
M30/31	22.0	24.4	41.5	9.2
M52/53	36.6	42.7	68.3	15.3
M73/74	52.5	61.0	99.5	22.0
M103/104	67.1	82.4	131.2	27.5
M148	112.9	137.3	189.2	41.5
M222	152.6	176.9	341.7	67.1
M295	218.5	241.0	415.0	86.7
M470	335.6	-	-	174.5
M586	416.2	476.0	790.2	174.5
M900	762.6	-	-	396.7
M1213	872.6	1013.0	1293.7	360.0
M2366	1586.6	1861.2	2471.5	701.8
M2958	1922.2	2288.4	-	1037.4
M3720	2955.0	-	-	1594.0

**ACTUATOR CYCLE TIME
90° ACTUATION**

NOTE: STROKE TIME IS EQUAL FOR OPENING
AND CLOSING STROKES

16-1 UNITORQ ACTUATOR MATERIAL TABLE

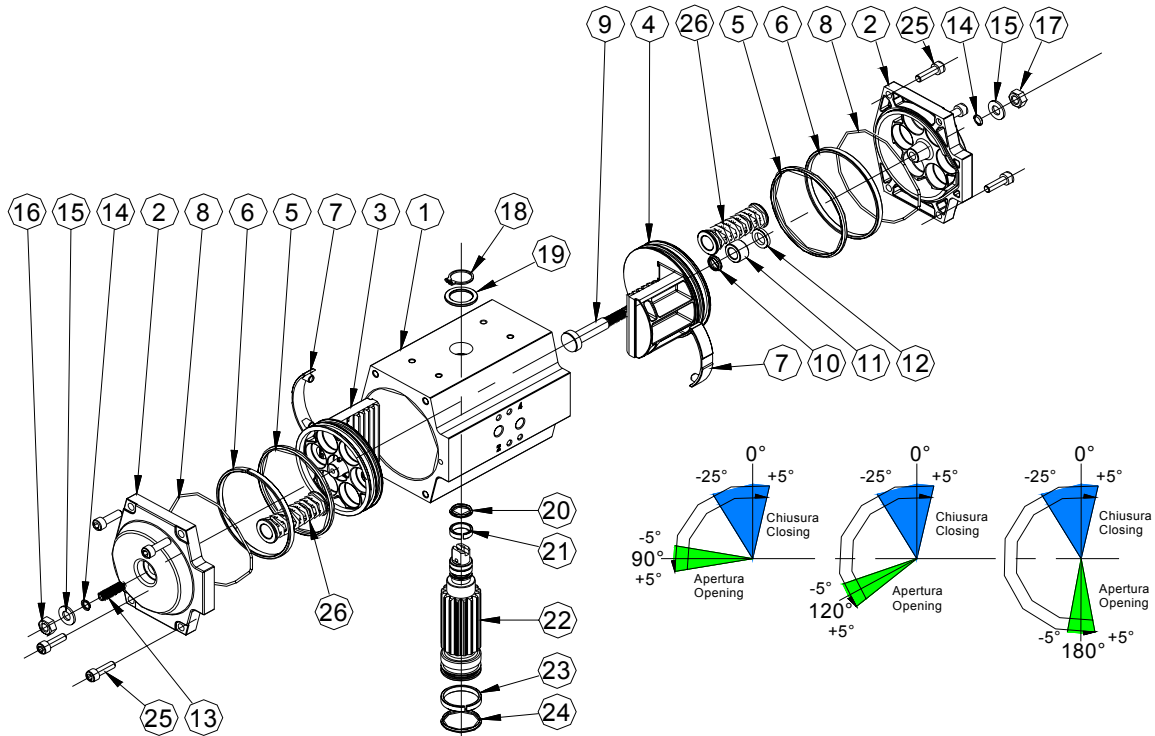

ITEM #	Qty	Description	Material
1	1	Body	Anodized Aluminum/Epoxy Painted
2	2	End Cap	Epoxy Coated Aluminum
3	1	Piston Std.	Die Cast Aluminum
4	1	Piston DLS	Die Cast Aluminum
5	2	Piston O-Ring	Buna N
6	2	Piston Guide	Delrin 500
7	1	Piston Skate	Delrin 500
8	2	End Cap O-Ring	Buna N
9	1	Internal Travel Stop Shaft	ANSI 304 Stainless Steel
10	1	Internal Stop Sealing O-Ring	Buna N
11	1	Internal Stop Guide Bushing	Teflon
12	1	DLS Shaft Guide Bushing Stop Washer	Aluminum Alloy
13	1	External Travel Stop Screw	ANSI 304 Stainless Steel
14	2	Travel Stop Seal O-Ring	Buna N
15	2	O-Ring Stop Washer	ANSI 304 Stainless Steel
16	1	External Stop Nut	ANSI 304 Stainless Steel
17	1	Internal Stop Nut	ANSI 304 Stainless Steel
18	1	Pinion Stop Circlips	Stainless Steel UNI 7435
19	1	Upper Pinion Washer	E.N.P. ASTM B656 Steel
20	1	Upper Pinion O-Ring	Buna N
21	1	Upper Pinion Guide	Delrin 500
22	1	Pinion	E.N.P. ASTM B656 Steel
23	1	Lower Pinion Guide	Delrin 500
24	1	Lower Pinion O-Ring	Buna N
25	8	End Cap Fasteners	ANSI 304 Stainless Steel
26	Max. 12	Spring Cartridge	Epoxy Coated Steel

WARRANTY

THE SELLER WARRANTS IT'S PRODUCTS AGAINST DEFECTS IN MATERIALS OR WORKMANSHIP, WHEN USED ON THOSE SERVICES APPROVED BY THE SELLER, FOR A PERIOD OF TWO YEARS FROM THE DATE OF ORIGINAL SHIPMENT. THE SELLER'S LIABILITY UNDER THIS WARRANTY SHALL BE LIMITED TO REPAIR OR REPLACEMENT AT SELLER'S OPTION OF SUCH PRODUCTS. F.O.B. FACTORY, UPON PROOF OF DEFECTS SATISFACTORY TO SELLER. SELLER MAKES NO WARRANTIES, EITHER EXPRESSED OR IMPLIED, EXCEPT AS PROVIDED HEREIN, INCLUDING WITHOUT LIMITATION THEREOF, WARRANTIES AS TO MARKETABILITY, MERCHANTABILITY, FITNESS FOR A PARTICULAR PURPOSE OR USE, OR AGAINST INFRINGEMENT OF ANY PATENT. IN NO EVENT SHALL SELLER BE LIABLE FOR ANY DIRECT, INCIDENTAL OR CONSEQUENTIAL DAMAGES OF ANY NATURE, OR LOSSES OR EXPENSES RESULTING FROM ANY DEFECTIVE PRODUCTS OR THE USE OF ANY PRODUCT.